

# LTE test bed

Bernt Johansson and Tomas Sundin

The Third Generation Partnership Project (3GPP) is specifying the long-term evolution of third-generation cellular systems to meet demands for higher user bit rates. Ericsson has thus developed a test bed to evaluate new access technologies and to investigate the suitability of new implementation technologies for future radio-access products.

The authors explain the access concept and anticipated requirements for LTE and describe the test-bed system, architecture, subsystems, and technology.

## Background

In September 2006, 3GPP finalized a study item called *Evolved UTRA* and *UTRAN*. The purpose of the study was to define the long-term evolution (LTE) of 3GPP access technology in order to keep it competitive even in the distant future.<sup>1,2</sup> A corresponding work item is scheduled for completion in the second half of 2007. The 3GPP also conducted a parallel study, called *System Architecture Evolution (SAE)*, to outline the evolution of the core network.<sup>3</sup>

## Introduction to LTE

The 3GPP study item began by setting requirements and defining the scope of LTE. Examples of these requirements are

- improved instantaneous peak data rates – 100Mbps in the downlink and 50Mbps in the uplink;
- reduced latency – less than 100ms transition from camped state to active state, less than 50ms transition from dormant state to active state, and less than 5ms IP packet latency in the user plane in an unloaded system;
- improved system performance – two- to four-fold increase in downlink bit rates compared with a basic release 6 system (HSDPA), and two- to three-fold increase in uplink bit rates compared with a basic release 6 system (E-DCH); and
- improved spectrum flexibility – ability to deploy the system in many different frequency bands, in paired and unpaired spectrum, and with different spectrum allocations (for example, 1.25, 2.5, 5.0, 10.0, 15.0 and 20MHz).<sup>4</sup>

The requirements were also used as input for determining the choice of air interface. To fulfill the requirements put on spectrum flexibility and peak data rates, the study item concluded that the air interface in the downlink should be based on orthogonal frequency-division multiplexing (OFDM). This approach yields a frequency structure

that splits data over a large number of individual subcarriers with a spacing of 15kHz. The smallest addressable unit, called a resource block, is defined as 12 consecutive subcarriers in frequency and 14 consecutive symbols in time. The resource block is thus 180kHz in the frequency domain and equal to 1ms (or one subframe) in the time domain. A subframe is also the minimum transmission time interval (TTI). Short TTIs favor the requirements put on latency in the user plane. The main method of fulfilling the requirements for peak data rates calls for the transmission of parallel streams of data to a single terminal using multiple-input multiple-output (MIMO) techniques.

For the uplink, the study item recommended a single-carrier-based frequency-division multiple access (FDMA) solution with dynamic bandwidth. This approach

allows for a power-efficient implementation of the user terminal. The basic parameters, such as subframe and TTI, match those of the downlink.

Ericsson's LTE test bed thus uses cyclic-prefix OFDM (CP-OFDM) technology in the downlink and localized or interleaved FDMA technology in the uplink. At present, in a single-stream configuration from a single mobile user to the radio base station (RBS), it supports transmission rates of up to nearly 80Mbps in the downlink and 25Mbps in the uplink. The addition of three more streams in the downlink will give the test bed a peak data rate of nearly 300Mbps.

The LTE test bed is currently limited to a single cell configuration without support for radio resource management, admission control, or handover between cells or sectors. Apart from basic radio and baseband (BB) capabilities, it implements medium access control (MAC), radio link control (RLC), and a simple interface to applications and services. It has also been prepared to work with advanced antenna solutions. Therefore, the LTE access network can optimize transmission according to a user's location and needs – that is, it can combine several streams, form beams (beamform-

## TERMS AND ABBREVIATIONS

3GPP	Third Generation Partnership Project	MAC	Media access control
AMC	Advanced mezzanine card	MCPA	Multicarrier power amplifier
ATCA	Advanced TCA	MIMO	Multiple input, multiple output
ATL	Application transport layer	MP	Main processor
AUM	Auxiliary unit module	MTU	Main timing unit
BB	Baseband	OAM	Operation, administration and maintenance
CBU	Cello basic unit	PA	Power amplifier
CP-OFDM	Cyclic-prefix orthogonal frequency-division multiplexing	PEC	Processor element cluster
CPP	Cello processor platform	RAS	Radio and antenna subsystem
DPD	Digital pre-distortion	RBS	Radio base station
DSP	Digital signal processor	RF	Radio frequency
eNB	Evolved Node-B	RLC	Radio link controller
FDMA	Frequency-division multiple access	RUIF	Radio unit interface
FFT	Fast Fourier Transform	RX	Receiver
FTP	File transfer protocol	RXIF	Receiver interface
FU	Filter unit	RXRF1	Receiver RF1
GPS	Global positioning system	RXRF2	Receiver RF2
I2C	Intelligent interface controller	SIMO	Single input, multiple output
IFFT	Inverse FFT	SISO	Single input, single output
IO	Input-output	TCA	Telecom computing architecture
IP	Internet protocol	TCP	Transport control protocol
L1, L2	Layer-1, layer-2	TOR	Transmit observation receiver
LTE	Long-term evolution of third-generation cellular systems	TRX	Transceiver
LTU	Local timing unit	TX	Transmitter
		UE	User equipment
		VoIP	Voice over IP

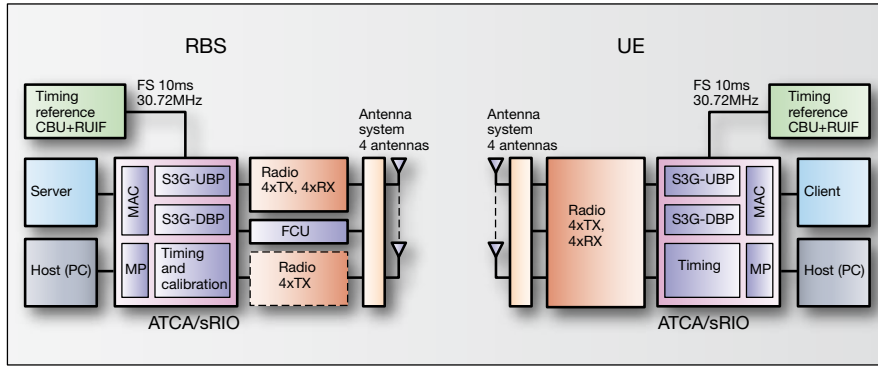

**Figure 1**  
Hardware architecture of the node-B and user equipment (UE).

ing) for longer range, or employ other combinations of transmission.

## The LTE test bed

Ericsson designed the LTE test bed around commercially available technology to provide a flexible, high-performance platform that can serve as the basis for the develop-

ment of layer-1, layer-2, and in time, layer-3 (L1, L2, L3) software functionality. The use of serial RapidIO technology, in particular, helps ensure platform flexibility.

The platform is based on advanced telecom computing architecture (ATCA) and advanced mezzanine card (AMC) processing boards. Together, these form a processor cluster. The test bed connects to an

application server and client via TCP/IP over Ethernet.

## LTE test bed structure

The LTE test bed is composed of an application server, radio base station, user equipment (UE), and host (Figure 1). From a hardware perspective, the base station and user equipment are more or less identical except that the antenna system in the UE has lower radio frequency (RF) output power.

A host processor, which handles the loading of software, debugging, and so on, is connected to both the RBS and UE. A server, which is connected to the RBS, and a client, which is connected to the UE, facilitate simultaneous applications, such as file transfer, VoIP, and streaming. In addition, the base station and UE have a highly stable timing and frequency reference that can be synchronized by means of GPS. The base station and UE are composed of

- an antenna subsystem that hosts power amplifiers, filters and antennas;
- an ATCA subsystem that hosts L1 and L2 processing, timing and calibration, a monitor, and the main processor (MP); and
- a radio subsystem that hosts up to four transceiver (TRX) units and a configurable 4x20W power amplifier (PA) module. The RBS may even support one additional radio subsystem (four transceiver units and configurable 4x20W PA module).

**Figure 2**  
Overview of the layered LTE test bed architecture.

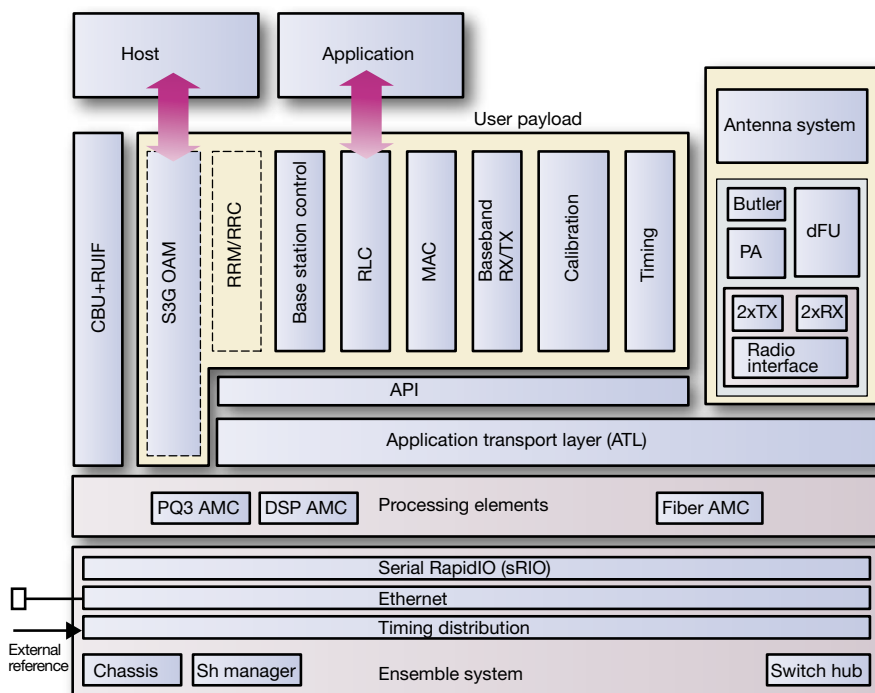

## Evolved node-B and UE architecture

Figure 2 shows the layered architecture of the LTE test bed. The ATCA (Ensamble system) platform provides serial RapidIO and Gigabit Ethernet; and from a reference source, it distributes timing between various processing elements, such as CPUs and DSP AMCs.

The application transport layer provides uniform communication between processor elements including the radio transceiver. Software applications, for instance, use it to communicate with one another.

The CBU generates a timing reference signal that radio unit interface (RUIF) boards distribute to the ATCA and transceiver. L1 and L2 signal processing is performed on top of the application transport layer.

Figure 3 shows an overview of the LTE node-B and UE architecture.

### System architecture

Figure 4 shows the hardware architecture of the LTE test bed, which is composed of four main building blocks:

- Cello processor platform (CPP);
- processor element cluster (PEC);
- radio and antenna subsystem (RAS);
- and
- mechanical structure.

Apart from some radio parts, the platform is completely programmable. It is thus very flexible in terms of adding or changing functionality. For instance, depending on equipment and cabling, the hardware architecture can support the following configurations:

- 1xSISO/SIMO (single input, single output/single input, multiple output);
- 2xMIMO (multiple input, multiple output); or
- 4xMIMO.

#### CPP

CPP includes standard product boards, such as CBU and RUIF. Looking ahead, it might also host special-purpose processor and Gigabit Ethernet interface boards. At present, CPP is solely used for distributing timing signals provided by CBU and RUIF.

The CBU selects either an internal CBU reference source or an optional external frequency reference source, such as a GPS device or a stable, free-running oscillator.

#### PEC

The processing element cluster (PEC) platform, which implements L1 and L2 functionality, is composed of a digital signal processor cluster, a main timing unit, and general-purpose processors. It has been built using ATCA technology to permit scaling and flexibility. The ATCA subrack contains mandatory connections made up of Gigabit Ethernet and intelligent interface controllers (I2C). In addition, serial RapidIO with four lanes, running at 3.125GHz per lane, is used as a fat pipe. It also holds several carrier boards, each of which has four slots for AMCs. The AMCs are interconnected via RapidIO and Gigabit Ethernet switch fabrics and an I2C hub. The AMC slots may be equipped with general-purpose processor AMCs, DSP AMCs, and interface AMCs. The PEC platform uses Gigabit Ethernet and the I2C system-management bus for OAM, software loading, and tracing and debugging purposes; the serial RapidIO is used as an interconnect for application data.

RBS/UE 19-inch main cabinet

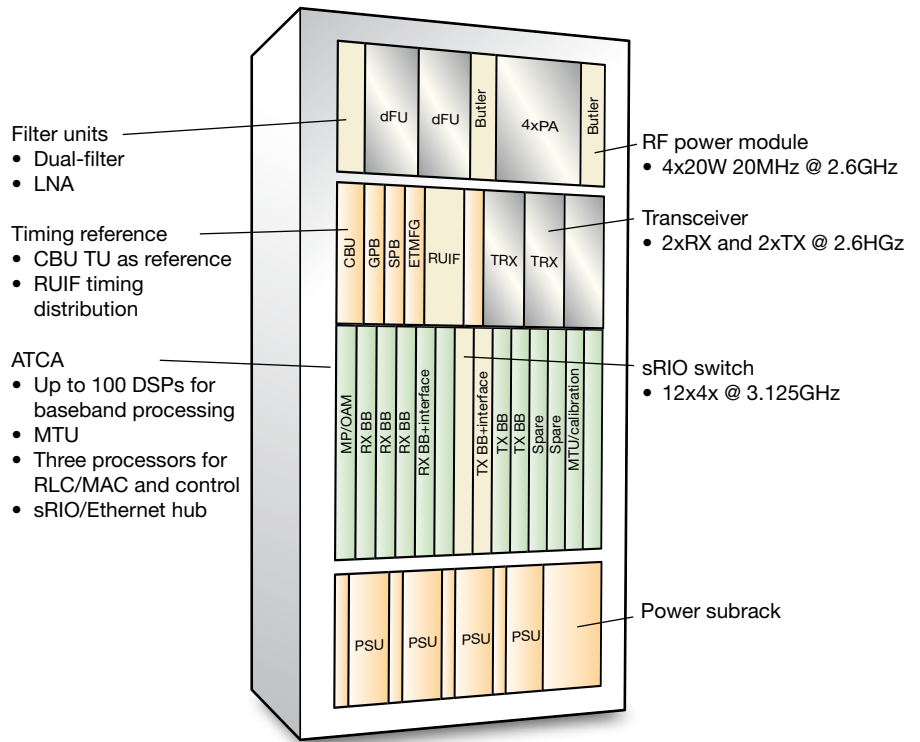

**Figure 3**  
Overview of the S3G node-B and UE architecture.

**Figure 4**  
Hardware architecture of the LTE test bed.

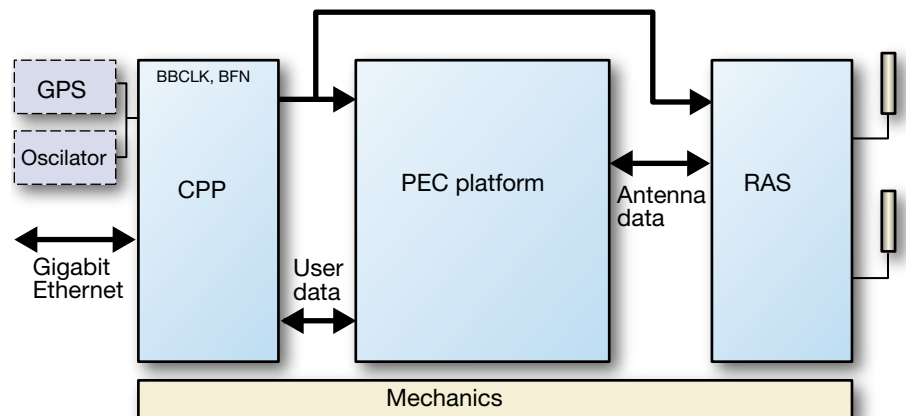

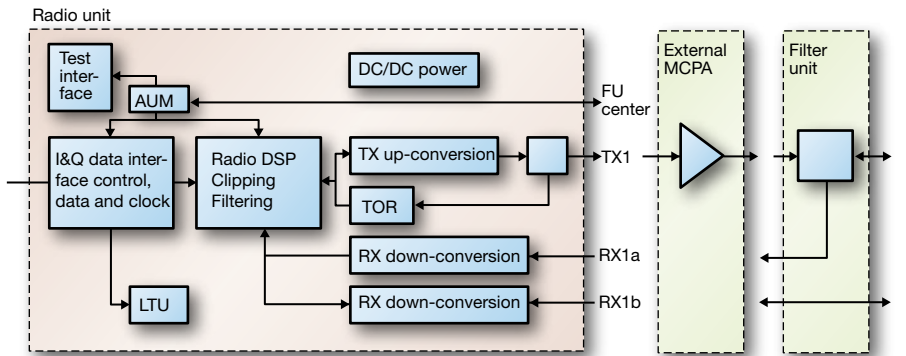

**Figure 5**  
Block diagram of the transceiver.

The development and host system connect to the ATCA subrack via Gigabit Ethernet. The radio subsystem connects to the PEC platform by means of a cable to an AMC with external interface. One AMC interface is required for each transceiver connected to the PEC.

The clock reference subrack, which consists of CBU and RUIF boards from standard RBS products, is connected to a main timing unit (MTU) allocated to an AMC in the ATCA subsystem. The MTU distributes clock and sync reference signals in the ATCA backplane and to the radio subrack.

#### Radio and antenna subsystem

The radio subsystem is composed of a

transceiver, power amplifier, filter, and optional calibration unit. One radio transceiver, which supports two transmitter (TX) and receiver (RX) chains, can support 2xMIMO per transceiver board. The power amplifier, which delivers up to 80W over 20MHz of operational bandwidth, can support SISO/SIMO, 2xMIMO or 4xMIMO configurations.

#### Management subsystem

The test bed employs a host processor with a graphical user interface (GUI) for control of software loading, system setup, debugging, and logging of data. All communication with the test bed is performed through the GUI. The GUI may also display a variety of

graphs. The host processor connects to the test bed via Gigabit Ethernet.

#### Application transport layer

The application transport layer constitutes an interface between the application layer and RapidIO logic layer. The application layer handles data message units; the RapidIO logic layer handles RapidIO packets. The main task of the application transport layer is to reassemble packets into message units and to segment message units into packets. The ATL implementation differs from processor element to processor element. The main functions of the application transport layer are message segmentation and reassembly, destination decoding, buffering, and interrupt handling.

#### Radio implementation

Figure 5 shows a block diagram of the transceiver and how it is connected to the power amplifier and filters.

The radio unit schematic shows units for transmitter up-conversion, receiver down-conversion, digital baseband processing, a digital signal interface, and control. Transmitter amplification is implemented through an external amplifier with a built-in linearization function. At present, linearization is carried out using feed-forward techniques and by subtracting the distortion signal. This robust technique gives excellent RF performance. A transmit observation receiver (TOR) is used for correcting imbalance in the transmitter analog mixer. The radio unit also includes receiver chains for two-way diversity.

The baseband radio DSP unit contains clipping and filtering functions. In addition, it has been prepared for digital pre-distortion (DPD) as a means of linearizing future, more power-efficient amplifiers. In this event, the TOR functionality can also be used for computing a proper pre-distortion signal. The local timing unit (LTU) functional block distributes a common reference clock in the radio unit for local oscillator synthesizers, such as TX, TOR, RXRF1, RXRF2 and RXIF.

The main components of the transceiver are the auxiliary unit module (AUM), filter unit (FU), transmit observation receiver (TOR), local timing unit (LTU), and multicarrier power amplifier (MCPA).

#### Baseband implementation

Figure 6 shows the L1 and L2 implementa-

**Figure 6**  
L1 and L2 implementation for the uplink.

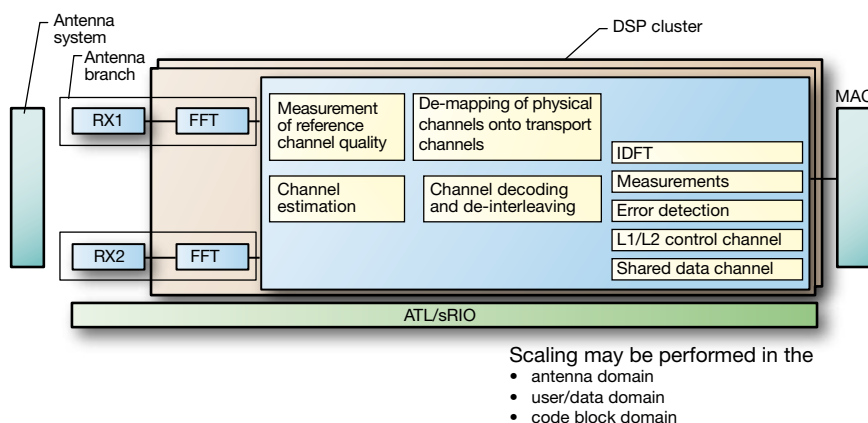

tion for the uplink. Figure 7 shows the L1 and L2 implementation for the downlink. These implementations are realized in software running on DSPs and general-purpose processors. The functionality, which makes use of the PEC platform and the ATL and serial RapidIO for interconnection between processors, is mapped onto the PEC platform at compile time.

The flexible mapping of functionality to processors makes it easy to scale the system to support more antenna branches for realizing 2xMIMO or 4xMIMO, or for adding support for more users or for higher bit rates. More DSP or general-purpose resources can be added by inserting more AMCs into the ATCA subrack.

#### System start

At startup, the system executes the OAM application, which communicates via RapidIO maintenance transfers with every device in the system, including endpoints, switches and bridges.

The main processor application uses the ATL message format to communicate through control channels with other functional units.

After hardware initialization and after OAM software and main processor application software have been loaded, the OAM application

- sets up the RapidIO transport layer; and
  - loads and starts other applications – for example, it loads applications in the DSP platform, radio link controller (RLC), media access control (MAC), and transceiver, and starts the main processor application.
- Once the system is set up, the main processor application configures the transceiver and starts the RLC, MAC, and baseband applications.

Software-defined functionality is allocated to processors at compile time. Once initialization is complete, the RBS begins transmitting synchronization pilot signals and the UE begins scanning for the synchronization channel.

#### Integration

To demonstrate LTE, Ericsson has deployed a small radio access network with one evolved node-B that handles one cell. When one transmit antenna is used, the test bed supports up to 80Mbps in the downlink. When four transmit antennas are used it supports up to 300Mbps in the downlink and can be used for concurrent FTP, VoIP and streaming data applications.

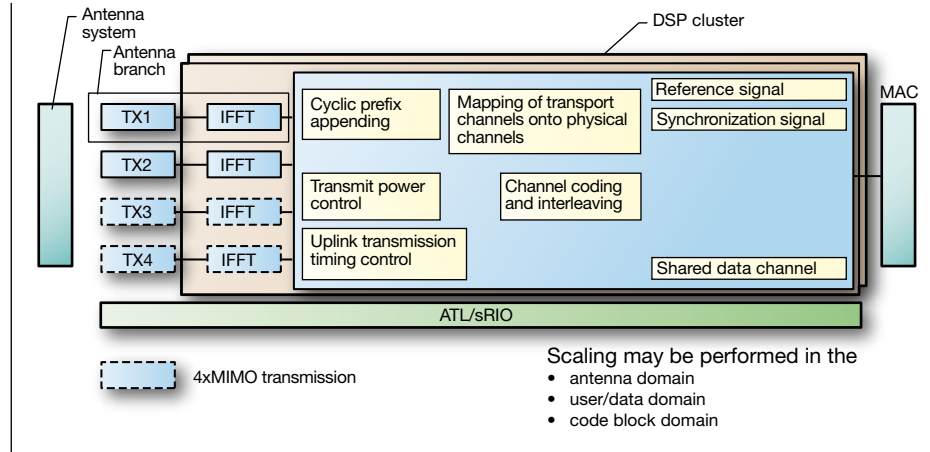

**Figure 7**  
**L1 and L2 implementation for the downlink.**

## LTE Evaluation

Ericsson will use the test bed to demonstrate the LTE concept, and to analyze performance and algorithms. The analysis will be based on measurements of radio channels and the radio link performance of various configurations.

## Benefits

The architecture of the LTE test bed is very flexible, making it easy to allocate and update functionality for a variety of configurations. It is also scalable, which translates into support for a wide variety of configurations with different hardware capability and capacity requirements. The test-bed architecture also easily supports logging and the storage of data for line evaluation.

## Conclusion

Ericsson has designed and built a test bed to demonstrate the LTE concept, and to analyze performance and algorithms. The analysis will be based on measurements of radio channels and the radio link performance of various configurations.

The LTE test bed is composed of an application server, radio base station, user equipment, and host. From a hardware perspective, the base station and user equipment are more or less identical.

The hardware architecture of the LTE test bed is composed of four main build-

ing blocks: CPP, processor element cluster, radio and antenna subsystem, and mechanical structure. Apart from some radio parts, the platform is completely programmable.

The air interface in the downlink is based on OFDM, which yields a frequency structure that splits data over a large number of individual subcarriers. The main method of fulfilling the requirements for peak data rates calls for the transmission of parallel streams of data to a single terminal using MIMO techniques.

The uplink uses a single-carrier-based FDMA solution with dynamic bandwidth. This approach allows for a power-efficient implementation of the user terminal.

## REFERENCES AND TRADEMARKS

1. TR 25.814, "Physical layer aspect for evolved UTRA"
2. TR 25.813, "Evolved Universal Terrestrial Radio Access (E-UTRA) and Evolved Universal Terrestrial Radio Access Network (E-UTRAN); Radio interface protocol aspects"
3. TR 23.882, "3GPP System Architecture Evolution (SAE): Report on Technical Options and Conclusions"
4. TR 25.913, "Requirements for Evolved UTRA (E-UTRA) and Evolved UTRAN (E-UTRAN)"

RapidIO is a registered trademark of the RapidIO Trade Association