

Ensemble MTI-203 RapidIO® DSP/FPGA Signal and Video Processing AdvancedMC™ Card

High-Performance AMC for Next-Generation Base-Station and Broadband Applications

- Supports 20-MHz WiMAX multi-antenna solutions on a single AMC
- Combined DSP and FPGA technology enables optimal application partitioning
- Exceptional flexibility and value for LTE and WiMAX base-station developers

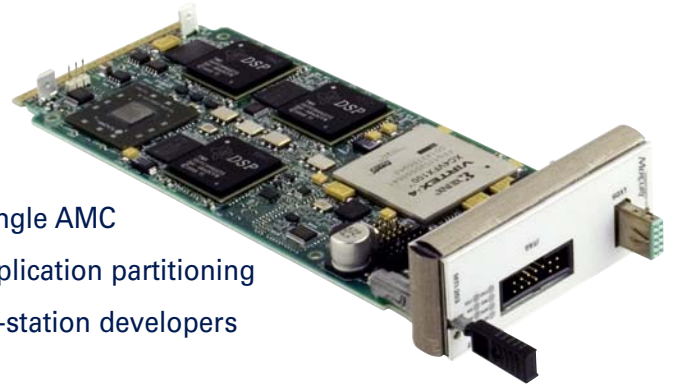

The Ensemble™ MTI-203 RapidIO® DSP/FPGA Signal and Video Processing AdvancedMC™ Card from Mercury Computer Systems is an ideal solution for developing and deploying LTE, WiMAX, next-generation video, or base-station applications. With three TCI6482 DSPs and a supporting Xilinx® FPGA node, the module enables all the physical layer (PHY) baseband processing required for a 20-MHz, TDD (time division duplex), multi-antenna solution with Smart Antenna MIMO (multiple input/output) enabled. As a baseband development platform, the MTI-203 is designed to support advanced features such as Smart Antenna and MIMO transmission across a variety of air interfaces.

WiMAX is an evolving standard (802.16x) for point-to-multipoint wireless networking. It can provide high-throughput connections over long-distance applications, including high-speed enterprise connectivity for businesses. The highly integrated MTI-203 module is designed to support the Texas Instrument (TI) WiMAX/802.16e infrastructure solution for wireless applications, which includes software, analog, and RF products from TI.

Combined DSP and FPGA Technology

At the heart of the MTI-203 are three Texas Instruments TMS320TCI6482 DSPs, running at 850 MHz each, and a Xilinx Virtex™-4 FX100 FPGA with dual integrated Power Architecture™ cores, running at 400 MHz. Combining DSPs and an FPGA on the same AMC module offers developers the ability to partition their applications using the most appropriate processing technology.

Flexible, High-Performance I/O Interfaces

The MTI-203 module communicates with the rest of the AdvancedTCA system via two 4x RapidIO fat pipes for data exchange and two 1-Gigabit Ethernet ports for configuration and control. The fat pipe from the FX100 FPGA is configurable as either

a 4x serial RapidIO link or a 10-Gigabit Ethernet port. The second fat pipe, which is from the Tsi578™ switch, is a 4x serial RapidIO link. Total peak bandwidth is 13.125 Gbps.

Ensemble AdvancedTCA Platform

The MTI-203 AMC expands the capabilities of the Ensemble family of blades and AMC modules to support highly integrated DSP/FPGA applications. The Ensemble Platform is a standards-based solution built around the power, functionality, and scalability of serial RapidIO, AdvancedTCA, and AMC. The platform supports a variety of I/O sources and heterogeneous processing, thereby reducing integration costs, improving efficiency, and minimizing risks in design of next-generation applications.

The Ensemble Platform has many advantages that accelerate application development activities:

- The variety of heterogeneous Ensemble AMCs allows developers to customize applications with options to plug in host processors, radio cards, or a network interface card (NIC) AMC.
- AMCs can be combined with Ensemble carrier boards that provide RapidIO chip-to-chip and across-the-chassis connectivity, enabling seamless scaling from a single-sector system to multi-sector, multi-antenna, multi-carrier base-station implementations.
- Ensemble offers developers the flexibility to easily expand specific processing nodes to address application performance bottlenecks; additional FPGA or DSP modules over RapidIO can be used to support specific application requirements.
- The homogeneous RapidIO interconnect among processing nodes enables ease of programming of DSPs, communication processors, and FPGAs.

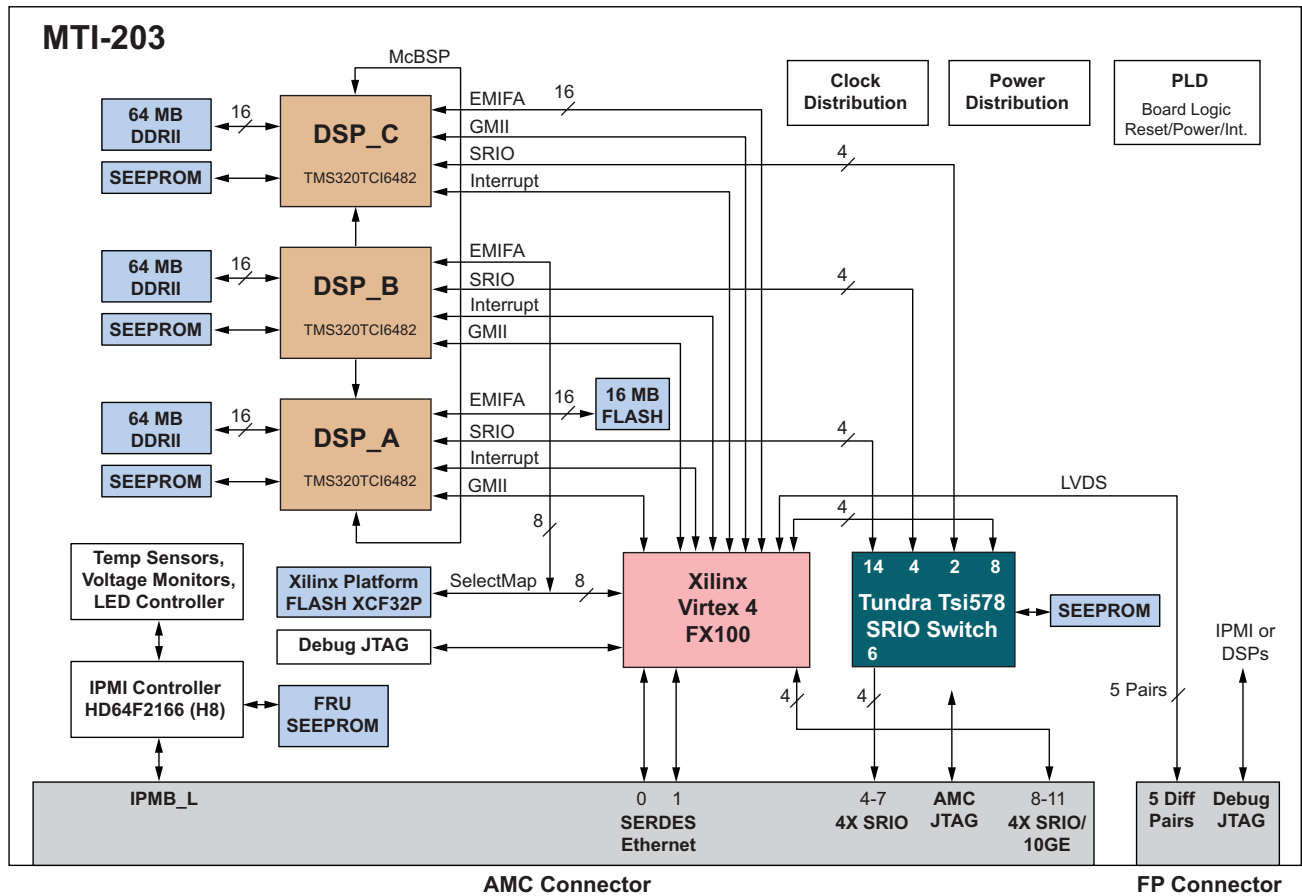

Figure 1. MTI-203 functional block diagram

Ensemble Configuration Options

Additional elements of the Ensemble Platform are listed below. Thermal considerations may limit full configurations in some situations.

- Ensemble 2-, 5-, and 14-slot AdvancedTCA chassis
- BCC-101 Serial RapidIO Quad AMC Carrier Blade
- BCE-100 FPGA AdvancedTCA Compute Blade
- BSW-101 AdvancedTCA RapidIO/GigE Switch Blade
- MFib-101 Dual 10-Gig Fiber and Ethernet AMC Interface Module
- MPQ-101 Serial RapidIO PowerQUICC™ AMC Module
- MTI-104 Quad TI DSP AMC Module

Specifications

Digital signal processors

Three TI TMS320TCI6482 DSPs 850 MHz

Serial RapidIO interfaces 1.25 Gb, 2.5 Gb, or 3.125 Gbps

JTAG/emulation support

2-wire EEPROM support

McBSP bus support

Code compatible with the TMS320C6455

RGMII Gigabit Ethernet supported on DSP_A and DSP_B

EMIF_A path from DSP_C to the FPGA

EMIF_A path from DSP_B to the FPGA SelectMAP to support reconfiguration

Field-programmable gate array (FPGA)

Xilinx Virtex-4 FX100 (compatible with Xilinx Virtex-4 FX60)

Reconfigurable from Xilinx platform flash (XCF32P)

LVDS bus support

One 4x serial RapidIO interface to serial RapidIO switch

One 4x serial RapidIO/10-Gigabit Ethernet interface to AMC connector

Memory

DDRII 250-MHz SDRAM per DSP 64 MB

16-bit DDRII interface

Flash (DSP_A) 16 MB

Serial RapidIO switch

Tundra® Tsi578™ 8-port serial RapidIO switch

Gbps support 1.25, 2.5, and 3.125

Ethernet

FX100 FPGA performs Gigabit Ethernet PHY functions between AMC Ports 0 and 1 and DSP_A and DSP_B, respectively.

IPMI

Hitachi® HD64F2166 IPMI controller

Voltage monitor

Geographical address monitor

Temperature monitors

Power/reset control

DSP and serial RapidIO switch EEPROM interfaces

FPGA and CFG CPLD interfaces

AMC connector

Dual 10/100/1000 Ethernet (Ports 0-1)

4x serial RapidIO (Ports 4-7)

4x serial RapidIO or 10-Gigabit Ethernet port (Ports 8-11)

IPMB-A and IPMB-B link

Front panel

Per AMC.0 LEDs on front panel

Out of service Red

User LED2 Green

User LED3 Yellow

Hot swap Blue

DSP LED for each DSP

Two FPGA LEDs

FPGA LVDS connector

JTAG debug connector

Reset push-button

Test and development

14-pin front-panel JTAG/emulator/programming connector for DSPs and IPMI

14-pin non-front-panel JTAG/emulator/programming connector for Xilinx FPGA and platform flash

4 AMC-specified LEDs

8 user-defined LEDs

Software support

Linux® variant 2.6 kernel 32- and 36-bit mode

Mechanical

Full- or mid-height AMC, single-width AMC

Width 28.96 mm

Depth 208.53 mm

Height 73.81 mm

Supports AMC B+ bays

Environmental

Temperature

Operating 0°C to 45°C at 10,000 ft

Storage -40°C to +85°C

Humidity

Operating 10-90% non-condensing

Vibration 0.003g²/Hz, 20-2000 Hz, 1 hr/axis

Shock x and y axes: 32g; z axis: 20g; 11 ms, half-sine

Power Consumption

12V payload 30W typical 40W max

3.3V management 0.25W typical 0.5W max

Specification compliance

AMC.0 Rev 2.0 compliant

Hot swap support

Ensemble and Challenges Drive Innovation are trademarks of Mercury Computer Systems, Inc. RapidIO is a registered trademark of the RapidIO Trade Association. Other products mentioned may be trademarks or registered trademarks of their respective holders. Mercury Computer Systems, Inc. believes this information is accurate as of its publication date and is not responsible for any inadvertent errors. The information contained herein is subject to change without notice.

Copyright © 2007 Mercury Computer Systems, Inc.

566.01E-0407-DS-mti203



Corporate Headquarters

199 Riverneck Road
Chelmsford, MA 01824-2820 USA
+1 (978) 967-1401 • +1 (866) 627-6951
Fax +1 (978) 256-3599
www.mc.com

Worldwide Locations

Mercury Computer Systems has R&D, support and sales locations in France, Germany, Japan, the United Kingdom and the United States.

For office locations and contact information, please call the corporate headquarters or visit our Web site at www.mc.com.