

MPC-102 Dual-Core 8641D AMC Module

Dual-Core Processing Power and Flexible High-Bandwidth I/O

- Freescale™ MPC8641D processor delivers up to 20 GFLOPS
- Fully compatible with both ATCA and μTCA Ensemble™ platforms
- Choice of serial RapidIO® or PCI Express® switch fabrics
- I/O of 16 Gbps handles streaming datasets



The Ensemble™ MPC-102 Dual-Core 8641D AMC Module from Mercury Computer Systems combines dual-core processing power and flexible I/O for AdvancedTCA® (ATCA) and MicroTCA® (μTCA) platforms. The MPC-102 supports an MPC8641D Power Architecture™ processor running at up to 1.33 GHz, combined with memory and I/O options for maximum application flexibility. The module is a single-width AMC, either mid-height or full-height, differing only by faceplate. It includes an IPMI controller, firmware, and IPMI links for chassis management-based control and configuration.

The MPC-102 is well suited to provide high-performance computing for applications as diverse as wireless base stations, wafer lithography, and test and measurement in telecom, industrial control, silicon inspection, and other industries.

Memory for Dual-Core Processing

The MPC-102 Module has a dual-core MPC8641D processor, 128 MB of NOR flash, and two DDR2 memory buses, one for each of the processor's independent memory controllers. Although each DDR2 memory bus has its own bank of memory, both banks of memory are available to both processing cores.

Switch-Fabric Choices

Switch-fabric communications via the AMC connector can use either serial RapidIO® or PCI Express®. For 1x/4x serial RapidIO (AMC fat pipe Ports 4-7), each link provides a peak data transfer rate of 2.5 Gbps, resulting in a peak aggregate transfer rate of nearly 10 Gbps for the 4x connection. The PCI Express fabric option is x8, x4, x2, x1 PCI Express at AMC fat pipe Ports 8-11 and 4-7. The mixed option has 4x serial RapidIO and x4 PCI Express at AMC fat pipe Ports 4-7 and 8-11.

Gigabit Ethernet and SATA

The module has four Ethernet connections: two to the front panel and two to the AMC connector. The front panel connections are 10/100/1000Base-T. The AMC connector supports dual 1000Base-BX Ethernet connections at AMC common option Ports 0-1. A serial ATA (SATA) interface to the AMC connector supports efficient movement of data to disk storage.

Ensemble Platform

The MPC-102 AMC Module contributes a cost-effective, high-performance dual-core processor to the Ensemble Serial RapidIO ATCA Platform. The Ensemble Platform is a standards-based solution built around the power, functionality, and scalability of serial RapidIO, AdvancedMC®, AdvancedTCA, and MicroTCA. The platform supports a variety of I/O sources and heterogeneous processing endpoints, thereby reducing integration costs, improving efficiency, and minimizing risks in design of next-generation applications.

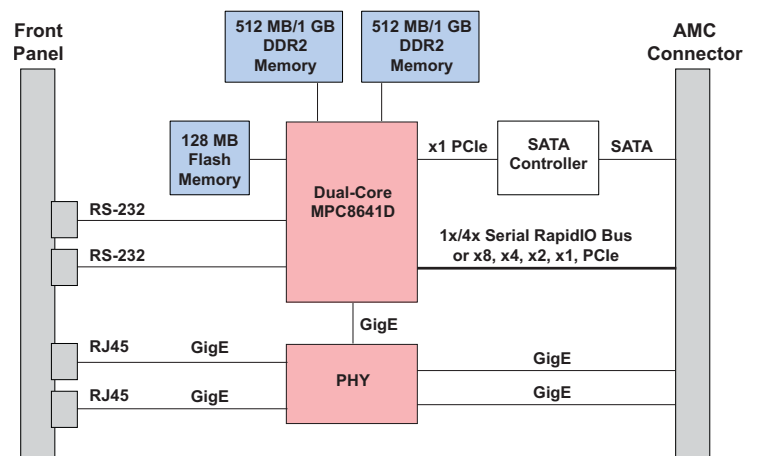

Figure 1. Ensemble MPC-102 block diagram

The Ensemble Platform has many advantages that accelerate application development activities:

- The variety of heterogeneous Ensemble AMCs allows developers to customize applications with options to plug in host processors, radio cards, or a network interface card (NIC) AMC.
- AMCs can be combined with Ensemble carrier boards that provide RapidIO chip-to-chip and across-the-chassis connectivity, enabling seamless scaling from a single-sector system to multisector, multi-antenna, multicarrier base-station implementations.
- Ensemble offers developers the flexibility to easily expand specific processing nodes to address application performance bottlenecks. Additional FPGA or DSP modules over RapidIO can be used to support specific application requirements.
- The homogeneous RapidIO interconnect among processing nodes enables ease of programming of DSPs, communication processors, and FPGAs.

Specifications

Processor

Freescale MPC8641D processor
Dual-core (e600) Power Architecture
Up to 1.33 GHz

Memory

Flash
128-MB NOR
DDR2 SDRAM
2 banks
Up to 1 GB each
Memory buses
2
Each at up to 533 MHz
64 bits wide

AMC connector

Switch-fabric options

1x/4x serial RapidIO

AMC fat pipe Ports 4-7

x8, x4, x2, x1 PCI Express

AMC fat pipe Ports 8-11 and 4-7, not AMC.1 compliant

Dual 1000Base-BX Ethernet connections

AMC common option Ports 0-1

Serial ATA (SATA) connection

AMC common option Port 2

IPMB

Renesas HD64-F2166 micro-controller

FRU 4-KB serial EPROM

Two NE1618DS temperature sensors with diodes

One external diode

One internal diode to the 8641D

IPMB-L 2-wire interface to carrier

Voltage monitoring

Front-Panel I/O

Two RJ45 10/100/1000Base-T Ethernet ports

MPC8641D UART via micro-DB9 and DB9 Y-cable

IPMI UART or second MPC8641D UART, jumper selectable

Mechanical

Full-height

Width: 73.81 mm; Depth: 180.6 mm; Height: 28.96 mm

Mid-height

Width: 73.81 mm; Depth: 180.6 mm; Height: 18.96 mm

Supports AMC B+ bays

Test and Development

16-pin JTAG MPC8641D emulator connector

14-pin JTAG/programming header for IPMI controller

ICT test points

Full JTAG chain from AMC connector

Power Consumption

Consult factory.

Software Support

Linux® and VxWorks® support

Ensemble and Challenges Drive Innovation are trademarks of Mercury Computer Systems, Inc. RapidIO is a registered trademark of the RapidIO Trade Association. Other products mentioned may be trademarks or registered trademarks of their respective holders. Mercury Computer Systems, Inc. believes this information is accurate as of its publication date and is not responsible for any inadvertent errors. The information contained herein is subject to change without notice.

Copyright © 2007 Mercury Computer Systems, Inc.

1299.00E-0807-DS-MPC102



Corporate Headquarters

199 Riverneck Road
Chelmsford, MA 01824-2820 USA
+1 (978) 967-1401 • +1 (866) 627-6951
Fax +1 (978) 256-3599
www.mc.com

Worldwide Locations

Mercury Computer Systems has R&D, support and sales locations in France, Germany, Japan, the United Kingdom and the United States.

For office locations and contact information, please call the corporate headquarters or visit our Web site at www.mc.com.